

# Life cycle assessment of EPS and CPB inserts: design considerations and end of life scenarios

Reginald B.H. Tan, Hsien H. Khoo\*

*Chemical and Environmental Engineering Department, National University of Singapore, 10 Kent Ridge Crescent, Singapore 119260*

## Abstract

Expanded polystyrene (EPS) and corrugated paperboard (CPB) are used in many industrial applications, such as containers, shock absorbers or simply as inserts. Both materials pose two different types of environmental problems. The first is the pollution and resource consumption that occur during the production of these materials; the second is the growing landfills that arise out of the excessive disposal of these packaging materials. Life cycle assessment or LCA will be introduced in this paper as a useful tool to compare the environmental performance of both EPS and CPB throughout their life cycle stages.

This paper is divided into two main parts. The first part investigates the environmental impacts of the production of EPS and CPB from ‘cradle-to-gate’, comparing two inserts—both the original and proposed new designs. In the second part, LCA is applied to investigate various end-of-life cases for the same materials. The study will evaluate the environmental impacts of the present waste management practices in Singapore. Several ‘what-if’ cases are also discussed, including various percentages of landfilling and incineration.

The SimaPro LCA Version 5.0 software’s Eco-indicator 99 method is used to investigate the following five environmental impact categories: climate change, acidification/eutrophication, ecotoxicity, fossil fuels and respiratory inorganics.

© 2004 Elsevier Ltd. All rights reserved.

*Keywords:* Life cycle assessment; Expanded polystyrene; Corrugated paperboard; Impact assessment; Design and end-of-life comparisons

## 1. Introduction

This paper investigates and compares the environmental impacts of the production and disposal of two types of materials. Life cycle assessment (LCA) will be introduced as an important tool to quantify the potential environmental loads during the products’ life cycle stages, from production to end-of-life.

The focus of the LCA is on expanded polystyrene (EPS) and corrugated paperboard (CPB). Both have been used extensively for many years in packaging, mainly as containers, shock absorbers or simply as inserts. The LCA case study is divided into two main parts. The first investigates the impact assessment of two different designs of both EPS and CPB. The second part presents various end-of-life scenarios.

## 2. Case study: EPS and CPB inserts

EPS has been widely used in many industries for more than 30 years. It is a white hard foam which is mostly used as a packaging material or as shock absorbers (inserts) for a wide range of applications, including packing of commercial and electronic goods. EPS is produced from a hydrocarbon monomer, called styrene. Air makes up approximately 95–98% of the overall content of the material.

It has outstanding shock absorbency which provides good protection to a broad range of goods or products. It is also lightweight and durable, possesses good thermal insulation, is resistant to chemical or corrosive reactions, and is cost effective to use and produce. An example of the use of EPS as shock absorbers or inserts is shown in Fig. 1.

CPB is another material that can be used in virtually the same applications as EPS. CPB is structured like a sandwich—with corrugated ‘wavy fluting’ medium lying between two pieces of smooth board on the outside making it a strong versatile packaging material. Nearly 95% of all

\* Corresponding author. Address: Chemical and Environmental Engineering Department, National University of Singapore, BLK E5 02-51, 4 Engineering Drive 4, Singapore 117576.

*E-mail address:* chekhh@nus.edu.sg (H.H. Khoo).

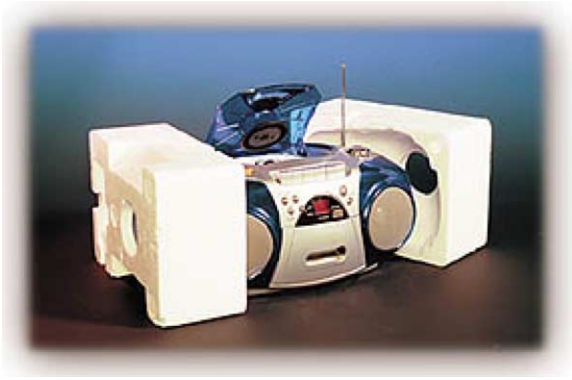

Fig. 1. EPS used for the protection of an electronic good.

the world's goods are shipped in corrugated containers. Apart from being used as a packaging material, they can also be used as shock absorbers for a wide range of commercial and household items, such as electronic goods.

This LCA study focuses on the use of EPS and CPB inserts for an electronic product, namely a tape recorder. The weight of the tape recorder is 200 g. The EPS and CPB inserts used to protect the tape recorder are shown in Fig. 2.

### 3. Life cycle assessment

Life cycle assessment (LCA) is an increasingly popular, multi-disciplinary and systematic tool used for measuring the potential environmental impact of a product or service (Guinee et al., 2001). An LCA can reveal the major areas of environmental concern, by focusing on the following:

- Studying the processes in a holistic manner
- Gathering data on the inputs and outputs of the processes involved
- Calculating and quantifying the environmental impacts based on a scientific and well defined methodology
- Classifying the environmental impacts, and most importantly
- Highlighting important areas for improvements in terms of environmental performance.

An environmental impact assessment can include midpoint or endpoint categories (Bare et al., 2000). An example of a midpoint category is the potential for global warming or climate change. Endpoint categories may include the change in seawater level due to climate change. The present paper will use LCA to evaluate midpoint impact categories.

According to the ISO 14040 series, an LCA study consists of four phases:

1. *Goal definition (ISO 14040)*: This forms the basis and scope of the subject or product of interest.
2. *Inventory analysis (ISO 14041)*: This involves collecting and analyzing the data concerning the relevant or main inputs (raw material and energy consumption) and outputs (emissions, wastes and product) of a well-defined system.
3. *Impact assessment (ISO 14042)*: The air and water emissions as well as raw material and energy consumptions are translated into environmental effects.
4. *Interpretation (ISO 14043)*: Conclusions are drawn from the LCA results, and areas for improvement are identified.

### 4. LCA study of EPS and CPB: cradle-to-gate

The raw material for EPS is non-renewable fossil fuel, while CPB originates from potentially renewable forests. The relative environmental benefits and shortcomings of renewable versus non-renewable packaging materials have been widely debated for years (Subramanian, 2000; Abbasi and Assasi 2004). In light of this, an LCA study of the two materials through their life cycle stages is proposed. In the first part, two different designs are compared—the original and new proposed designs. The design dimensions are displayed in Figs. 3 and 4. The goal and scope of the study, as well as the system boundary, is described as follows.

#### 4.1. Goal and scope (I)

The goal and scope of the study is to compare two different EPS and CPB inserts used as internal protective

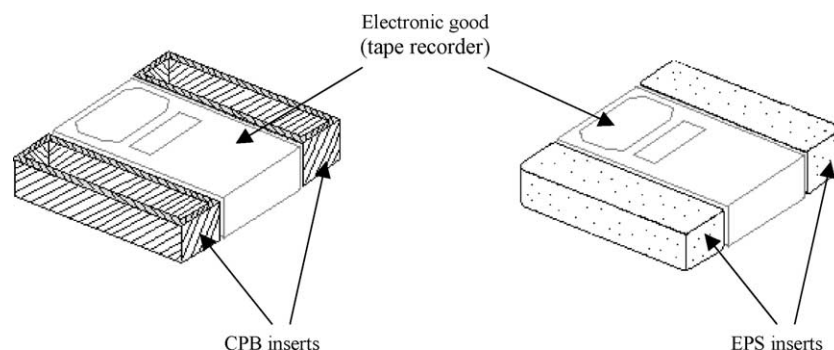

Fig. 2. CPB and EPS inserts (protective layers).

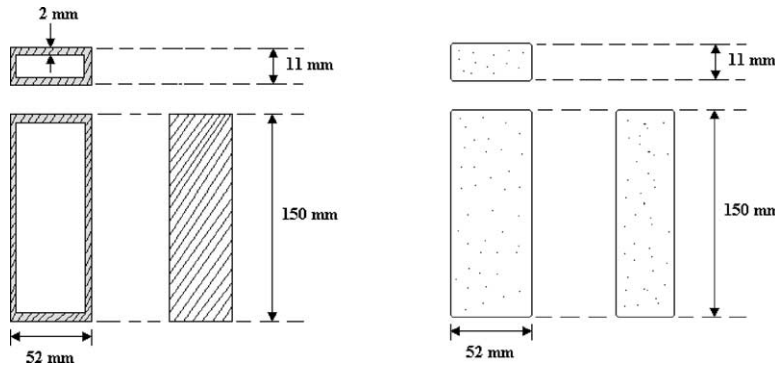

Fig. 3. Dimensions of original CPB and EPS inserts.

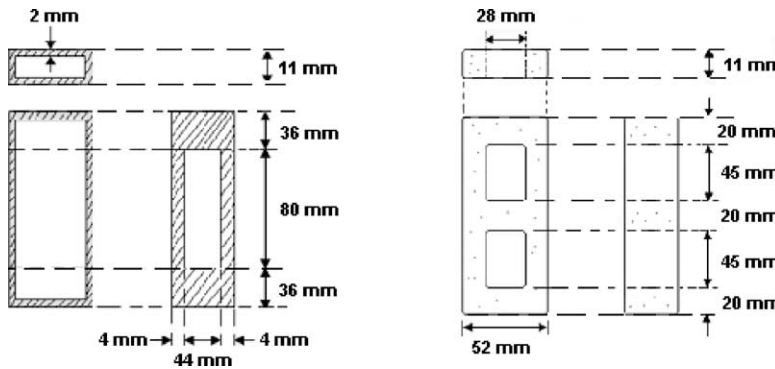

Fig. 4. Proposed EPS and CPB designs.

layers for a tape recorder. The original designs are illustrated in Fig. 3. The total volumes of the materials used are 35.4 cm<sup>3</sup> for CPB and 85.8 cm<sup>3</sup> for EPS. The densities of the materials are 0.15 g/cm<sup>3</sup> for CPB and 0.02 g/cm<sup>3</sup> for EPS. In the first LCA study (‘cradle-to-gate’), the weights of the original EPS and CPB inserts required to perform the same protective function are 1.716 and 5.310 g, respectively. The first LCA study will compare the environmental impacts of the production and transportation of the two materials.

In the new proposed designs, as shown in Fig. 4, less material is used. The LCA study will be carried out to compare the original CPB and EPS designs, as well as the proposed designs. The proposed designs are envisaged to provide the same internal protective function of holding the tape recorder securely in the box. This is because at all times, the main sides of the electronic product will be cushioned against impact or shock. The new proposed designs require 0.6072 g of EPS and 3.198 g of CPB. For the new CPB design, the cutout part may be reused for other purposes, such as shredded material for pets’ bedding.

4.2. System boundary (I)

The system boundary for the cradle-to-gate study is described in Fig. 5. A system boundary defines the limit or the interface between a series of processes or activities that

take place to produce the product of interest (e.g. EPS and CPB), and the environment. In the system boundary, the raw materials and energy used to produce both inserts, as well as emissions to air and water are taken into account. More detailed process descriptions for both EPS and CPB material can be found in EUMEPS (2002) and Zabaniotou and Kassidi (2003). After production, the inserts will be

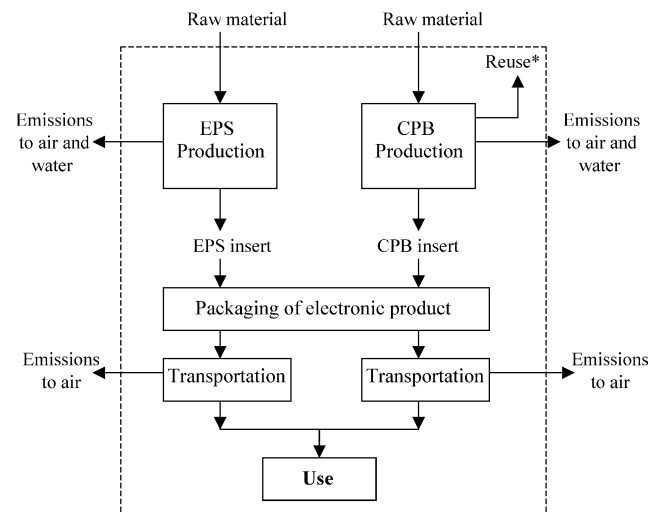

\*For the newly designed CPB insert, the cutout part is reused

Fig. 5. System boundary for ‘cradle-to-gate’. \*For the newly designed CPB insert, the cutout part is reused.

Table 1  
Main resources consumed for the production of 1.716 g EPS and 5.310 g CPB

Main resources (g)	EPS	CPB
Aluminums hydroxide	0	0.020
Bauxite	0.0019	0
Coal	0.15	0.01
Crude oil	0.00369	0.0012
Glue	0	0.0019
Ink	0	0.0029
Lignite	0.038	0.64
Nitrogen	0.053	0
Natural gas (in m <sup>3</sup> )	0.003	0.001
Starch (potatoes)	0	0.0032
Wood (eucalyptus)	0	0.47

packaged together with the electronic product into a box, which provides the external packaging. It is assumed that the same amount of energy is spent in the packaging of the electronic product for both inserts, therefore the impact assessment for this stage will not be taken into account. The packaged product is delivered to the end user by truck. The distance from the manufacturing plant to the consumer is estimated to be 20 km. In the LCA, zero pollution is assumed for the 'use' stage.

#### 4.3. Life cycle inventory (I)

The Life cycle inventory (LCI) data are sourced from various secondary databases. In order to ensure the quality of the data, the information gathered was published no earlier than the year 2000. For some of the LCI values, data from more than one source was gathered and compared. This was done to guarantee the data's accuracy and completeness.

For EPS production, the LCI data were taken from European Manufacturers of EPS packaging (EUMEPS) (2002), with some supplementary facts derived from Huntsman Chemicals (2002). As for CPB, the data were extracted from the European Database for Corrugated Paperboard Life Cycle Studies (2000) and LCA of

Table 2  
Emissions to air for the production of 1.716 g EPS and 5.310 g CPB

Air emissions (mg)	EPS	CPB
CO	2.37	3.53
CO <sub>2</sub>	1045.0	967.2
CH <sub>4</sub>	7.074	2.26
NO <sub>x</sub>	19.0	9.15
SO <sub>x</sub>	11.85	6.44
H <sub>2</sub> S	0.001	0.21
Hydrocarbons	6.86	0
Metals	0.01	0.0012
F <sub>2</sub>	0.000002	NA
H <sub>2</sub>	0.14	NA
Pentane	0.00007	0
VOCs	NA	0.083

NA, not available.

Table 3  
Emissions to water for the production of 1.716 g EPS and 5.310 g CPB

Water emissions (mg)	EPS	CPB
COD	1.15	3.82
BOD	0.24	4.78
Suspended solids	1.22	1.33
Dissolved solids	0.082	NA
Hydrocarbons	0.12	NA
NH <sub>4</sub> <sup>+</sup>	0.019	0
Phenol	0.002	0
Al	0.077	0
Ca	0.002	0
Cu	0.002	0.00042
Hg	0.001	0.000005
Na	1.20	0
Ni	0.0017	0.0024
Pb	0.001	0.0027
Zn	0.00002	0.0003
SO <sub>4</sub>	0.041	NA
CO <sub>3</sub>	0.27	NA
NO <sub>3</sub>	0.0007	0.27
NH <sub>3</sub>	0	0.040
Phosphate (P <sub>2</sub> O <sub>5</sub> )	0.009	0.066

NA, not available.

Paperboard Packaging in Thailand (AIT, 2001). As both EPS and CPB production includes the use of crude oil, LCI data for crude oil air emissions (mainly CO, CO<sub>2</sub>, NO<sub>x</sub> and SO<sub>x</sub>) from the Association of Plastics Manufacturers in Europe (APME, 2002) is also included. It was estimated that the total amount of energy required for production was 83 MJ for 1 kg EPS (EUMEPS, 2002) and 24 MJ for 1 kg CPB (AIT, 2001).

The LCI results for the production of 1.716 g of EPS and 5.310 g CPB, from cradle-to-gate, are shown in Tables 1–3. The material weights of the original and re-designed inserts are used as reference flows for the first LCA investigation. Transportation data was extracted from OECD and Hetch (1997) and is shown in Table 4.

## 5. Impact assessment (1)

The SimaPro's LCA Version 5.0 software for the *Eco-indicator 99* ('*hierarchist*' version) method for impact assessment is used to analyze the following five environmental impact categories: climate change, acidification/eutrophication, ecotoxicity, fossil fuels (resources) and respiratory inorganics.

The impact assessment involves three main steps: (i) *characterization* or *classification*, (ii) *normalization* and (iii) *final weighted scores*. In the first step, the LCI data are sorted into classes (environmental impact categories) according to the effect they have on the environment.

In the Eco-indicator 99 method, *normalization* and *weighting* are performed at what is known as a damage

Table 4  
Truck transport emissions

Pollutant (g/tonne km)	CO <sub>2</sub>	CO	SO <sub>2</sub>	NO <sub>x</sub>	HC	VOC	Particulates
Truck	289	1.33	0.265	3.75	0.94	1.1	0.47

category level. There are three damage categories for the final weighted scores:

- (1) *Human health*. This is measured in DALY (Disability adjusted life years); that is, the different disabilities caused by diseases are weighted. Climate change is categorized under this damage category.
- (2) *Ecosystem quality or ecotoxicity*. This is measured in PDF\*m2yr, which is the Potentially Disappeared Fraction of plant species. The impact category of acidification/eutrophication is listed here. In terms of ecotoxicity, this is measured as the percentage of all species present in the environment living under toxic stress (Potentially Affected Fraction or PAF\*m2yr).
- (3) *Resources*. This final damage category is measured in MJ surplus energy, which includes fossil fuels.

The normalization and weighting values are displayed in Table 5.

6. Results and discussion (I)

The results for climate change, acidification/eutrophication, ecotoxicity, fossil fuels and respiratory inorganics are

Table 5  
Eco-indicator 99—normalization and weighting values

Environmental impact categories	Damage category	Normalized values	Weight
Climate change (DALY)	Human health	65.1	300
Respiratory inorganics (DALY)	Human health		
Ecotoxicity (PAF*m2yr)	Ecosystem quality	$1.95 \times 10^{-04}$	400
Acidification (PDF*m2yr)	Ecosystem quality		
Fossil fuels (MJ Surplus)	Resources	$1.19 \times 10^{-04}$	200

displayed in Figs. 6–10, respectively. On the whole, all the scores for EPS are higher than for CPB where ‘production’ is concerned. However, since EPS is lighter than CPB, the impact from transportation of EPS is less. Variations in the impact categories from the original to the newly designed inserts can be observed.

For climate change (Fig. 6), the main load comes from the production of the original EPS insert, which is approximately 15% higher than that of CPB. However, due to Transportation of the original CPB insert, the scores become almost equal. It is interesting to note that after re-design, the contribution to climate change has become higher for the new CPB, as compared to the new EPS. This is because more material and resources are saved for the new EPS insert. Also for the new CPB insert, the Reuse stage (shredding) takes up approximately 10–20% of the amount of energy that is spent for the production stage.

Emissions of NO<sub>x</sub> and SO<sub>x</sub> are the main cause of acidification/eutrophication. As displayed in Fig. 7, the total loads from production and transportation of the original EPS

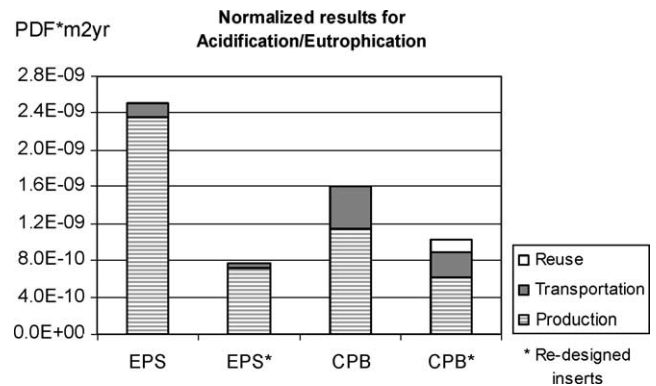

Fig. 7. Normalized results for acidification/eutrophication.

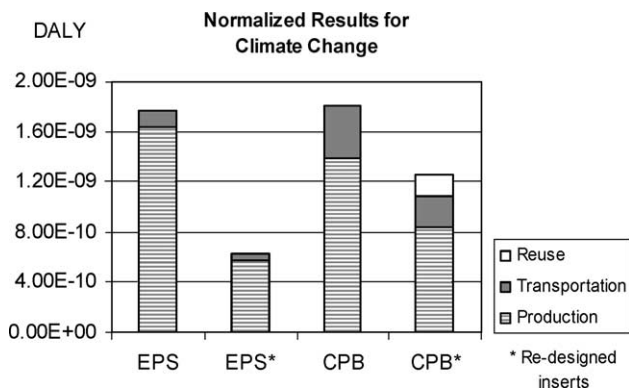

Fig. 6. Normalized results for climate change.

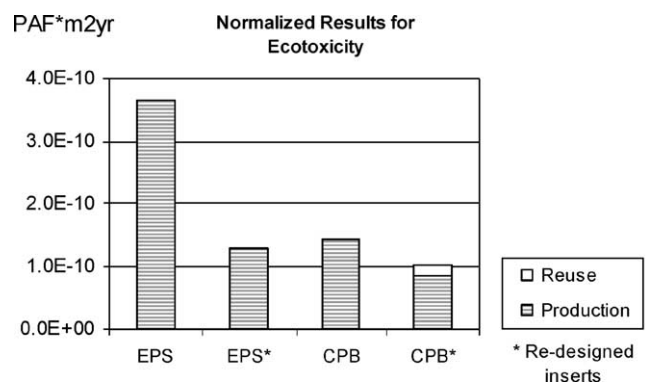

Fig. 8. Normalized results for ecotoxicity.



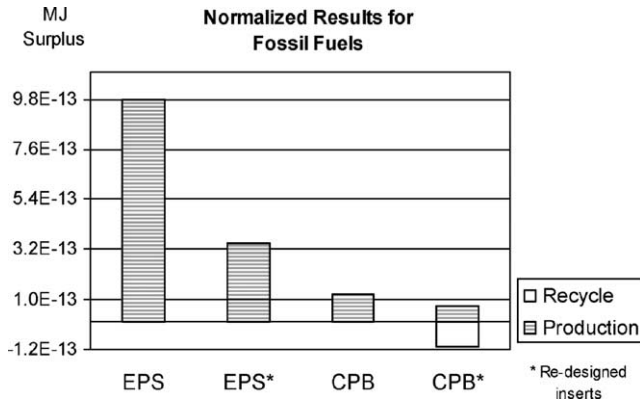

Fig. 9. Normalized results for fossil fuels.

insert add up to 30% higher scores for this impact category as compared to the original CPB insert. The potential environmental load of the proposed EPS insert dropped by nearly 70%. The total environmental load from the original to the proposed design for CPB dropped by about 30–40%.

The water emissions from production of the original EPS insert containing heavy metals such as copper and zinc have led to very high scores for ecotoxicity (Fig. 8), which turned out to be nearly 60% higher than that of CPB. The transportation of the two materials does not contribute to this environmental impact category. In the proposed design, this impact category for EPS decreased by a significant amount of 60%.

From the original to the new EPS design, the fossil fuels impact category (Fig. 9) saw a drastic drop in the environmental load, by about 65%. The original CPB insert consumes nearly 90% less resources during production than the original EPS insert. As for the newly proposed CPB, the negative peak shown on the graph is due to the raw material saved from the recycled CPB. Therefore, the potential net environmental affect for this impact category is negative. Transportation does not play a part in generating any results for this impact category.

In Fig. 10, the results for Respiratory Inorganics are from the emissions of particulates, NO<sub>x</sub> and SO<sub>x</sub> due to the transportation of EPS and CPB by truck. Compared to EPS,

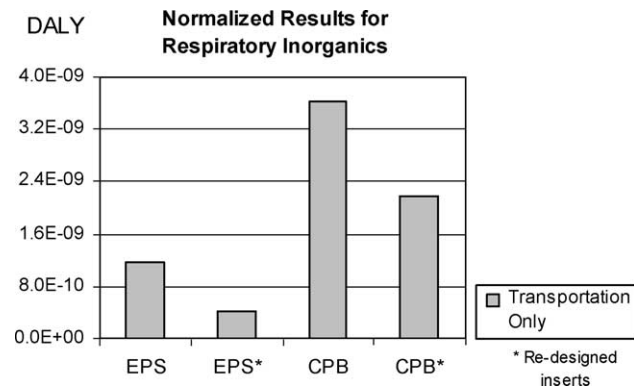

Fig. 10. Normalized results for respiratory inorganics.

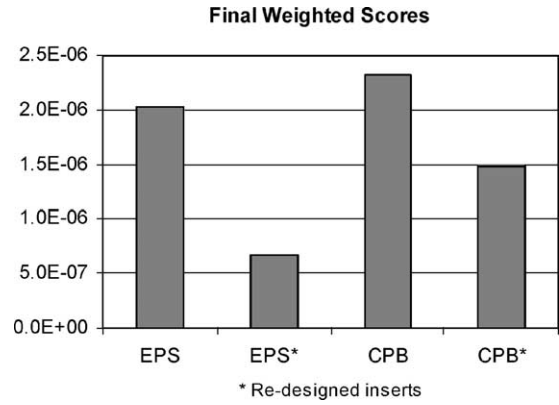

Fig. 11. Cradle-to-gate: final weighted scores.

the heavier weights of the CPB material generate approximately 60–70% higher environmental impacts for both cases.

The final weighted scores, for the cradle-to-gate comparison, are shown in Fig. 11. This graph presents the overall environmental burdens for both EPS and CPB production and transportation systems. For the original designs, CPB displayed a higher total environmental load. These scores are due to the higher environmental impact values placed on climate change and respiratory inorganics, as shown in Table 5. Although some resources are saved due to the reuse of some of the CPB material, the newly proposed CPB inserts do not promise as much potential environmental benefit. As a result of greater weight and material savings, the proposed EPS insert potentially generates about 70% lower environmental overall load, as compared to the original EPS insert. Therefore it is more beneficial to produce the new EPS insert than the new CPB insert.

### 7. End-of-life scenarios

In the second LCA study, several end-of-life scenarios of the same (original) two products are investigated. The LCA study is carried out in the context of Singapore, where the waste management option that is gaining favor for the country is incineration. Presently, the daily solid waste disposed of in Singapore is about 8000 tonnes whereas 73% of the waste is incinerated (Bai and Sutanto, 2002). Currently, there are no schemes to recycle packaging materials. Nor is there any waste collector registered with the National Environmental Agency (2003) to reclaim or take-back the EPS and CPB inserts for re-use. Based on this situation, it is assumed that the rest of the inserts (27%) will go to landfills.

There are four incineration plants that are operating in Singapore and the fifth is expected to be completed in the year 2004. It is estimated that out of the total 73% of the solid waste incinerated in the country, each plant accepts an

equal amount, that is, 18.25%. This means that when the fifth plant is fully in operation, the incineration rate can increase to an approximate amount of 91.25 or 90%.

In the LCA, the ‘current practice’ will be compared with other ‘what-if’ waste scenarios, including the projected incineration rate of 90%. For the second LCA, the reference flows of the original EPS and CPB designs are used (1.716 g EPS and 5.310 g CPB). The new LCA goal, scope and system boundary are as follows.

### 7.1. Goal and scope (II)

In the next LCA study, the following ‘what-if’ waste cases for the two materials are compared:

- 100% landfill (Case 1)
- 100% incineration (Case 2)
- 50% landfill and 50% incineration (Case 3)
- Current practice of 27% landfill and 73% incineration (Case 4)
- Projected 90% incineration and 10% landfill (Case 5).

### 7.2. System boundary (II)

The system boundary from the first LCA study is extended to include use, transportation, incineration and landfill, as shown in Fig. 12. For incineration, the estimated distance from the waste collection site to the Incineration plant at Tuas is 25 km. The used inserts are sent there by truck. As for landfilling, the used inserts are carried by truck

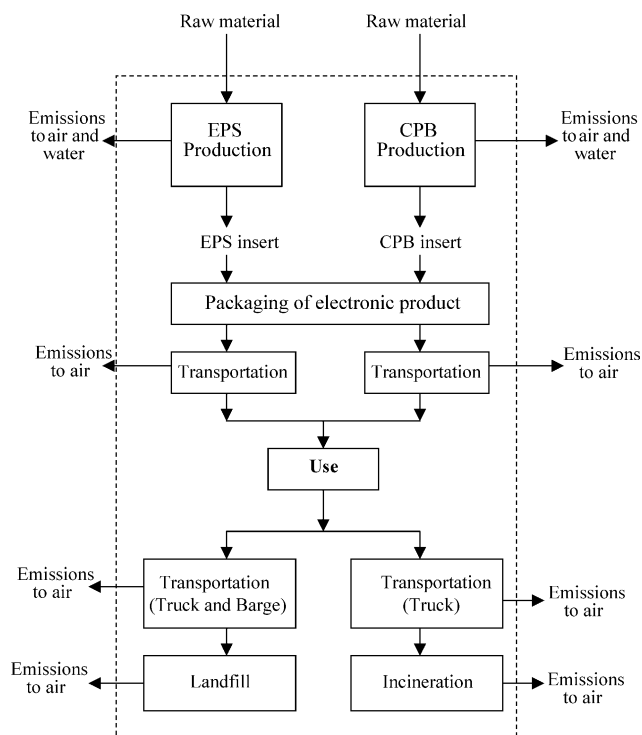

Fig. 12. System boundary for ‘cradle-to-grave’.

Table 6  
Emissions to air due to landfill (for reference flow of 1.716 g EPS and 5.310 g CPB)

Emissions to air (mg)	EPS	CPB
CO	0.070	3.01
CO <sub>2</sub>	87.47	1323.04
CH <sub>4</sub>	24.41	58.11
SO <sub>x</sub>	0.11	2.55
NO <sub>x</sub>	0.069	5.01

for a distance of 28 km to Tuas Marine Transfer Station, and then delivered to Semakau landfill by barge. The estimated distance traveled by the barge from the shore to the island is 25 km.

### 7.3. Life cycle inventory (II)

The LCI for the production of EPS and CPB, from ‘cradle-to-grave’, is adopted from the previous cradle-to-gate LCA study. Data for the rest of the LCI, or the products’ end-of-life, focused mainly on air emissions of carbon dioxide (CO<sub>2</sub>), methane (CH<sub>4</sub>), oxides of sulfur (SO<sub>x</sub>) and oxides of nitrogen (NO<sub>x</sub>) from landfills and incineration, and dioxins from incineration.

The LCI data for landfill emissions (displayed in Table 6) are extracted from AIT (2001) and Bez et al. (1998). The data for emissions from incineration are extracted from the National Atmospheric Emissions Inventory (NAEI, 2002) and Bjarnadóttir et al. (2002). These are summarized in Table 7. The transport emissions for trucks are displayed in Table 4 and for ships, Table 8.

By employing a state-of-the-art type of incineration technology, it is estimated that 40.66 MJ per 1 kg EPS (Huntsman Chemicals, 2002) and 16.45 MJ per 1 kg CPB (HP Packaging, 2003) are recoverable as part of the incineration process.

## 8. Impact assessment, results and discussion (II)

The same impact assessment method (Eco-indicator 99) is used. The ‘cradle-to-grave’ results for climate change, acidification/eutrophication, ecotoxicity, fossil fuels and respiratory inorganics are displayed in Figs. 13–17, respectively.

Table 7  
Emissions to air due to incineration (for reference flow of 1.716 g EPS and 5.310 g CPB)

Emissions to air (mg)	EPS	CPB
CO <sub>2</sub>	47.19	146.03
CH <sub>4</sub>	0.00014	0.00042
NO <sub>2</sub>	0.18	0.57
SO <sub>2</sub>	0.016	0.051
Dioxins	$4.90 \times 10^{-08}$	$3. \times 10^{-08}$

Table 8  
Ship (barge) transport emissions

Pollutant (g/tonne km)	CO <sub>2</sub>	CO	SO <sub>2</sub>	NO <sub>x</sub>	HC	VOC	Particulates
Marine transport	35	0.11	0.03	0.42	0.06	0.075	0.03

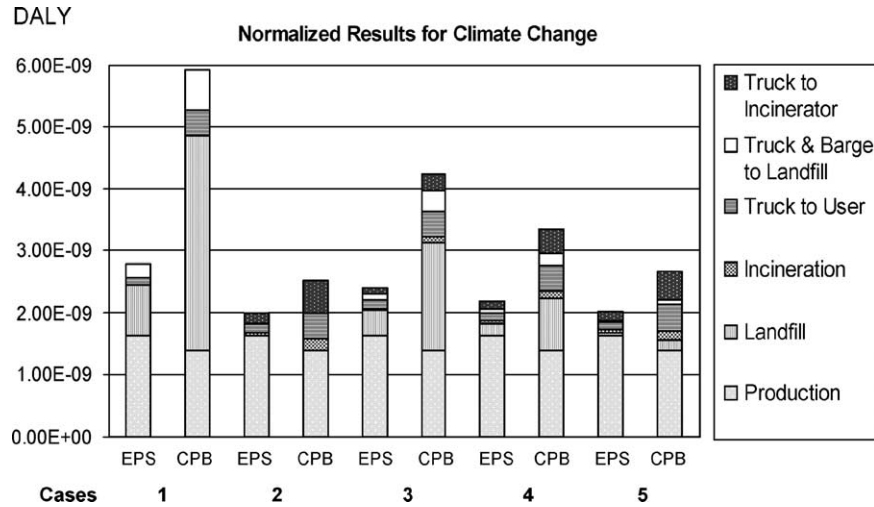

Fig. 13. Cradle-to-grave: normalized results for climate change.

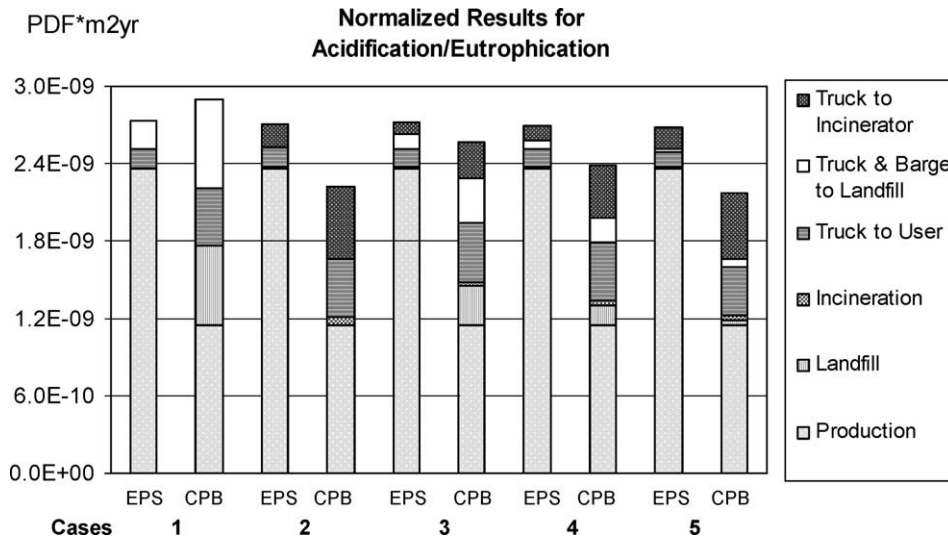

Fig. 14. Cradle-to-grave: normalized results for acidification/eutrophication.

In landfills, the carbon dioxide and methane emissions for cardboard waste are much higher than those of plastics. For climate change (Fig. 13), the landfill emissions from CPB displayed extremely high environmental loads for Case 1, where 100% of the material goes to landfills. The next worst case for CPB is Cases 3 (50% incineration). It is also observed that the production stage takes up a considerable portion of all the graphs. Also for all cases, transportation of EPS (from production to ‘end-of-life’ stage) bears less environmental burden than the transportation of CPB.

Except for Case 1, EPS displayed a higher contribution than CPB to acidification/eutrophication (Fig. 14). It can be observed that for EPS, the emissions of SO<sub>x</sub> and NO<sub>x</sub> originated mostly from the production stages, and much less from transportation, landfilling or incineration. On the contrary, the environmental impacts from production of CPB are relatively less, but higher scores can be noticed from the environmental impacts of transportation and landfilling.

In Fig. 15, the main contribution to ecotoxicity is from the production and incineration of EPS. The worst scenario



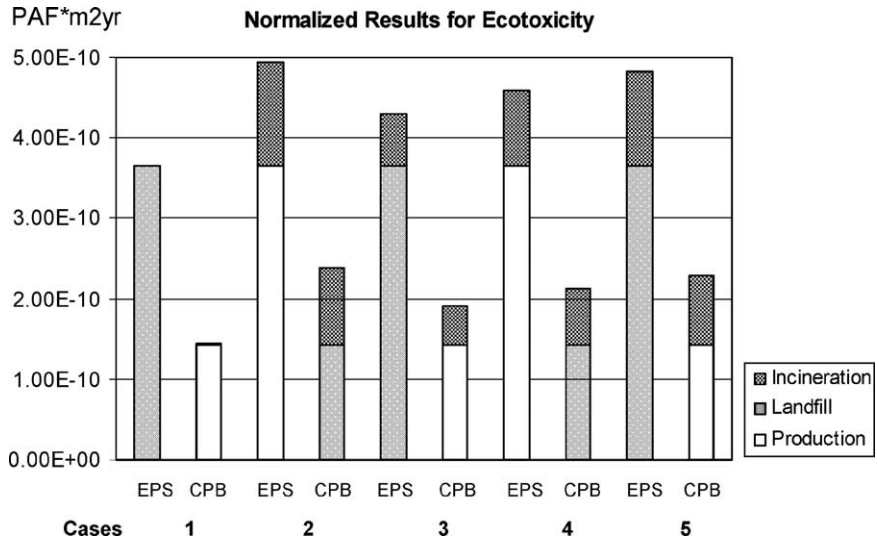
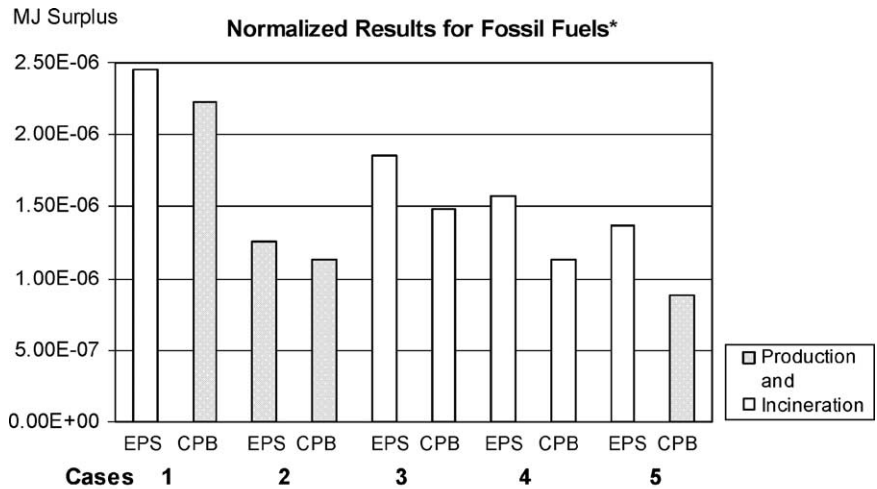

Fig. 15. Cradle-to-grave: normalized results for ecotoxicity.



\* Total Energy Required for Production minus energy obtained from incineration

Fig. 16. Cradle-to-grave: normalized results for fossil fuels.

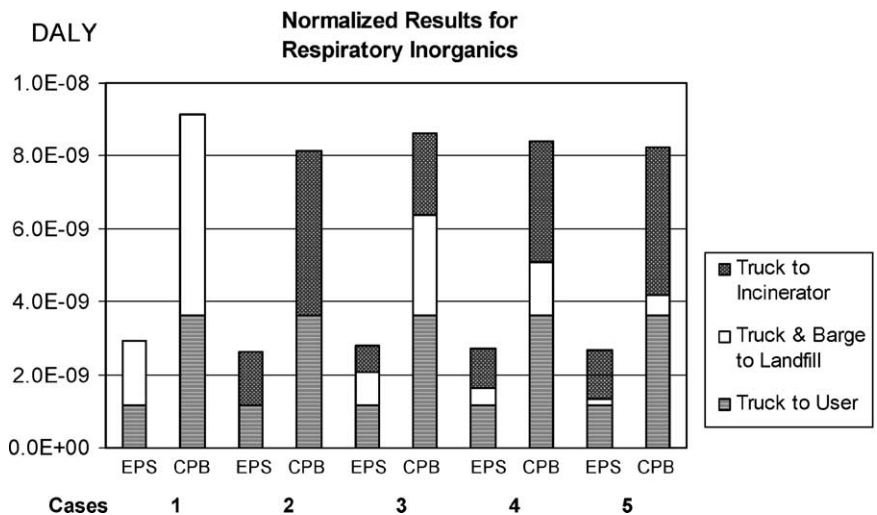

Fig. 17. Cradle-to-grave: normalized results for respiratory inorganics.

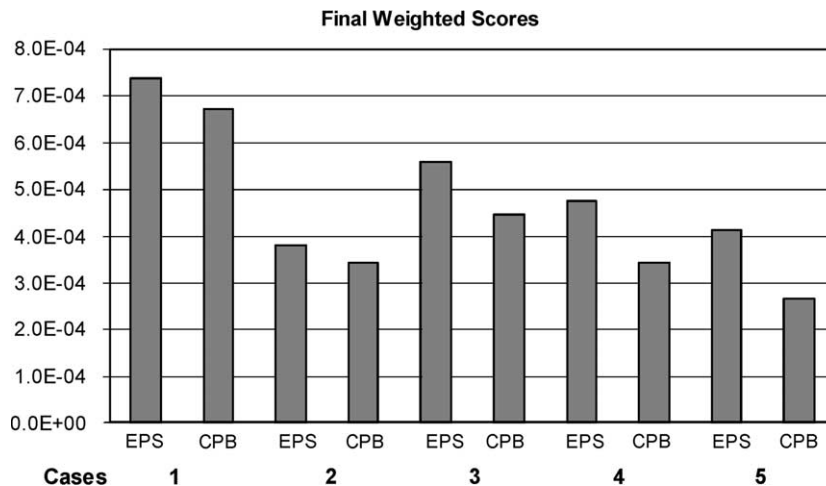

Fig. 18. Cradle-to-grave: final weighted scores.

is Case 2, where the plastic is 100% incinerated. Therefore, as the nation proceeds to increase the incineration rates from 73 (Case 4) to 90% (Case 5), tight regulations should be employed to restrict the level of dioxin emissions. Compared to EPS, the contribution from CPB to this impact category is much less in all five cases.

Fig. 16 presents the net fossil fuels consumed during the products' entire life cycle. These values include the amount of energy (in MJ) used for production minus the amount recovered from incineration. Although a higher amount of energy can be obtained from EPS due to incineration, which is approximately 60% higher on the same mass basis, the final amount recovered in this case is not much, due to the lightness of EPS (only 1.716 g as compared to 5.310 g) used as the insert. As expected, a higher percentage of material incinerated results in more energy conserved for the products' life cycle stages. Nearly half the amount of the energy can be saved for producing both EPS and CPB inserts when 100% of both materials are incinerated (Case 2).

Fig. 17 displays the results for Respiratory Inorganics for the life cycle of the two materials due to transportation alone. For all five cases, the scores for CPB are approximately 60% higher than EPS. This is due to the heavier weight of the material that has to be carried. The worst scenario is Case 1 (100% landfill), where the used CPB has to be delivered by truck to Tuas Marine Transfer Station, and then by barge to Semakau island.

The comparisons of the final weighted scores for Cases 1 to 5 are displayed in Fig. 18. Cases 2 (100% incineration) and 5 (90% incineration, 10% landfill) both display the least overall damage caused to the environment. The worst case for both EPA and CPB materials is Case 1 (100% landfilling). From here, it can be confirmed that the main environmental impacts for the inserts are dominated by greenhouse gases

generating from landfills, combined with the transportation modes required to deliver the used material to the landfill destination.

## 9. Conclusion

As the world's industrial activities increase, so does the demand for packaging materials. This calls for an urgent need to re-think how packaging materials could be produced and disposed of in a more environmentally-benign manner, hence causing the least harmful impact on the planet. In this context, Life Cycle Assessment or LCA has been widely accepted as a decision support tool in many production as well as waste management areas (Høgaas Eide, 2002; Guinee et al., 2001).

LCA was used to investigate, quantify and compare the potential environmental impacts of the life cycles of two packaging materials, EPS and CPB inserts. The first LCA cradle-to-gate study and impact assessment results highlighted quantitatively the environmental benefits of re-designing the products to consume less material. The next LCA study explored various waste scenarios for EPS and CPB inserts, displaying the positive and negative environmental impacts of landfilling and incineration options, as well as transportation. In conclusion, the least overall damage caused to the environment for the 'cradle-to-grave' study of both EPS and CPB comes from increased incineration practices (90–100%), and the worst from landfilling.

## References

- Abbasi, G.Y., Abbasi, B.E., 2004. Environmental assessment for paper and cardboard industry in Jordan—a cleaner production concept. *Journal of Cleaner Production* 12 (4), 321–326.

- AIT (Asian Institute of Technology), 2001. *Cradle to Grave: How Products Impact Natural Systems*. Pathumthani, Thailand.
- Association of Plastics Manufacturers in Europe (APME), 2002. Retrieved 8th June 2004 from [www.apme.org/](http://www.apme.org/)
- Bai, R., Sutanto, M., 2002. The practice and challenges of solid waste management in Singapore. *Waste Management* 22, 557–567.
- Bare, J., Hofstetter, P., Pennington, D., Udo de Haes, H., 2000. Midpoints versus endpoints: the sacrifices and benefits. *International Journal of Life Cycle Assessment* 5 (6), 319–326.
- Bez, J., Heyde, M., Goldhan, G., 1998. Waste treatment in product specific life cycle inventories: an approach of material-related modelling. *International Journal of Life Cycle Assessment* 3 (2), 100–105.
- Bjarnadóttir, H.J., Frióriksson, G.B., Johnsen, T., Sletsen, H., 2002. Guidelines for the use of LCA in the waste management sector, NORDTEST Report TR 517.
- EUMEPS (European Manufacturers of EPS Packaging), 2002. Retrieved 8th June 2004 from [www.eumeps.org/](http://www.eumeps.org/)
- European Database for Corrugated Paperboard Life Cycle Studies, 2000. Retrieved 8th June 2004 from <http://www.kartongatervinning.se/>
- Guinee, J.B., Huppes, G., Heijungs, R., 2001. Developing and LCA guide for decision support. *Environmental Management and Health* 12 (3), 301–310.
- Høgaas Eide, M., 2002. Life cycle assessment (LCA) of industrial milk production. *International Journal of Life Cycle Assessment* 7 (2), 115–126.
- HP Packaging, 2003. Environmentally responsible packaging. Retrieved 8th June 2004 from <http://packaging.hp.com/>
- Huntsman Chemicals, 2002. Expanded polystyrene (EPS) and the environment, Technical Bulletin 2-2.1. The Society of the Plastics Industry, Inc.
- National Atmospheric Emissions Inventory, 2002. Emissions of air pollutants in the UK. Retrieved 8th June 2004 from [www.naei.org.uk/](http://www.naei.org.uk/)
- National Environmental Agency, 2003. Retrieved 8th June 2004 from <http://app.nea.gov.sg/>
- OECD, Hetch, J., 1997. The environmental effects of freight. Organization for Economic Cooperation and Development (OECD), Paris, France.
- Subramanian, P.M., 2000. Plastics recycling and waste management in the US. *Resources, Conservation and Recycling* 28 (3–4), 253–263.
- Zabaniotou, A., Kassidi, E., 2003. Life cycle assessment applied to egg packaging made from polystyrene and recycled paper. *Journal of Cleaner Production* 11, 549–559.